

THIS DRAWING IS UNPUBLISHED. RELEASED FOR PUBLICATION
 © COPYRIGHT BY TYCO ELECTRONICS CORPORATION. ALL RIGHTS RESERVED.

LOC	DIST	REVISIONS					
GP	00	P	LTR	DESCRIPTION	DATE	DWN	APVD
		D		REVISED PER ECO-08-008760	30JUL2008	ZMRC	CWR

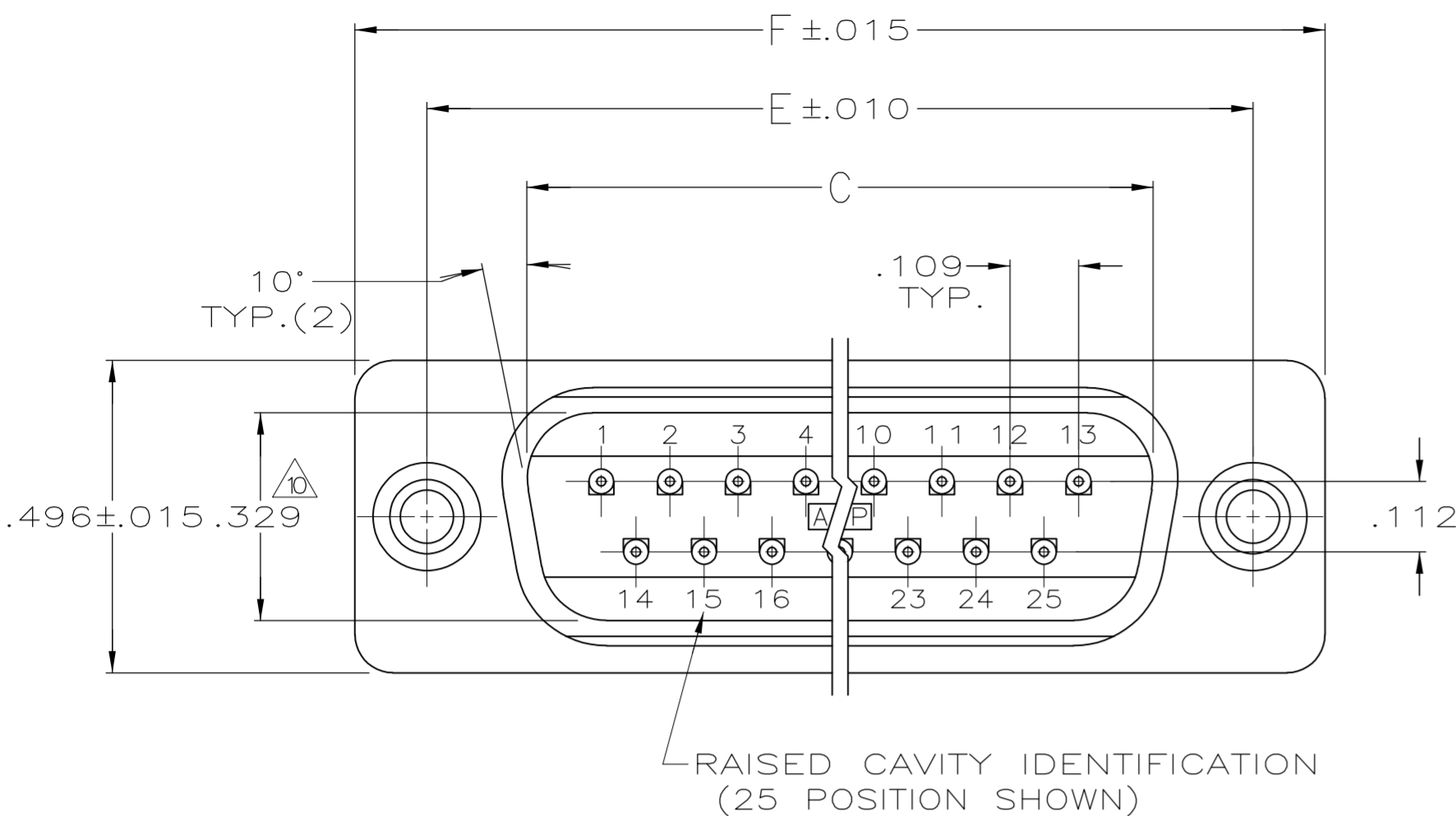

- CONNECTORS COMPLY WITH AMP SPEC. 108-40012 AND MATE WITH ANY SAME NUMBER POSITION PLUG CONNECTOR IN AMPLIMITE SERIES.
- CONNECTOR DESIGNED FOR 28 AND 26 AWG STRANDED AND SOLID CONDUCTOR RIBBON CABLE ON $.050 \text{ } \phi$.
- $\triangle 3$ DIMENSION APPLIES TO TERMINATED CONNECTOR.
- $\triangle 4$ INSERTS WILL WITHSTAND 6 IN. LBS. TORQUE AND 50 LBS. PULL OUT FORCE FROM MATING FACE SIDE.
- $\triangle 5$ MOLDED PARTS: FLAME RETARDANT 94V-0 RATED THERMOPLASTIC; COLOR: BLACK.
- $\triangle 6$ PHOS. BRONZE PER QQ-B-750.
- $\triangle 7$ BRASS PER MIL-C-50.
- $\triangle 8$ GOLD PLATING PER MIL-G-45204, TIN PLATING PER MIL-T-10727, NICKEL PLATING PER QQ-N-290.
- $\triangle 9$ CONTACTS:
 .000030 GOLD ON MATING END, .000100-.000200 MATTE TIN ON TERMINATION END, ALL OVER .000050 NICKEL ON ENTIRE CONTACT.
 OR
 GOLD FLASH OVER PALLADIUM-NICKEL ON MATING END, .000030 MIN TOTAL, .000100-.000200 MATTE TIN ON TERMINATION END, ALL OVER .000050 NICKEL ON ENTIRE CONTACT.
- $\triangle 10$ DIMENSION APPLIES TO BASE OF SHROUD.

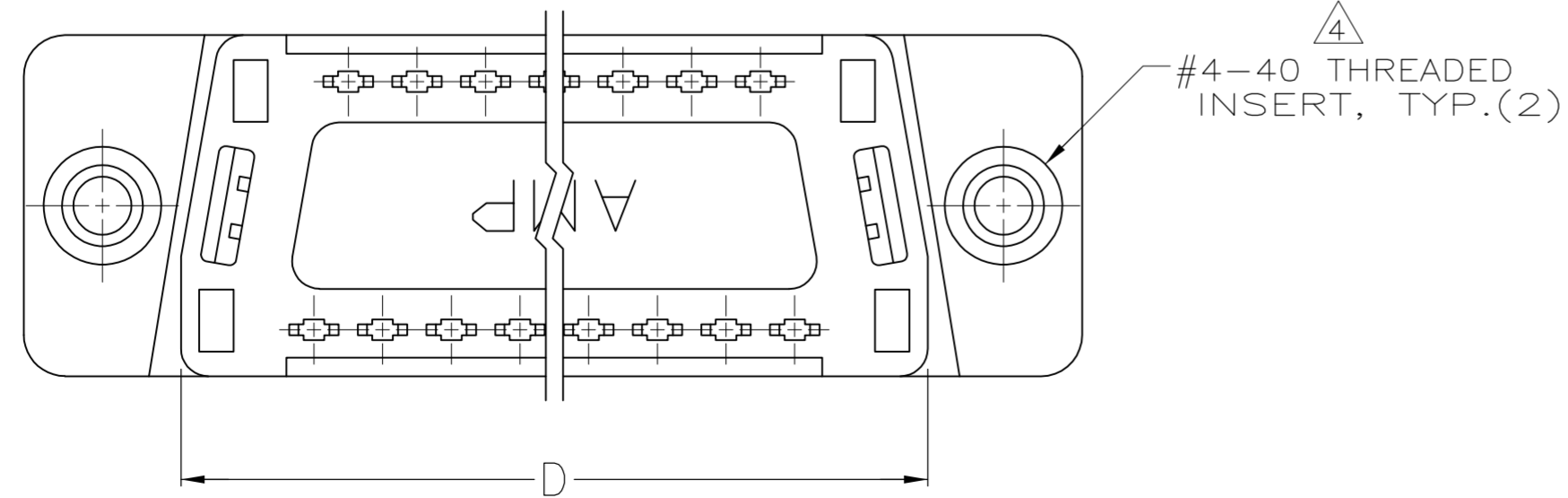
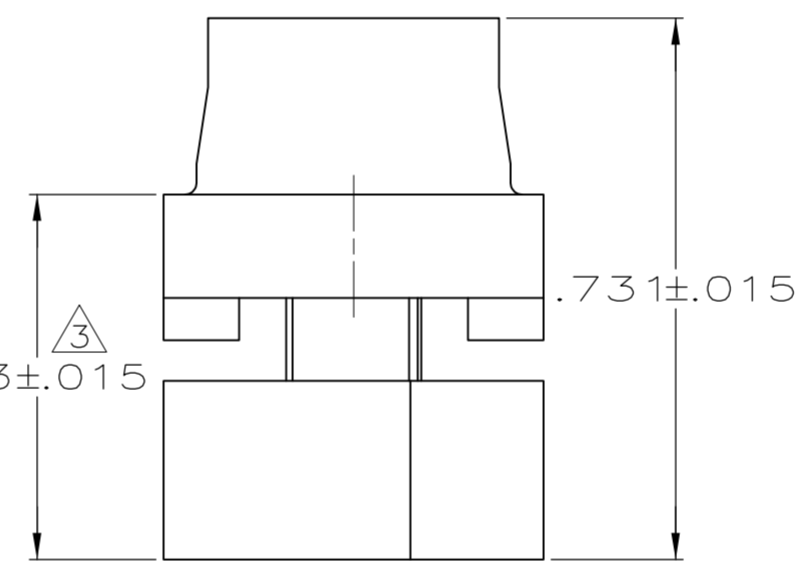
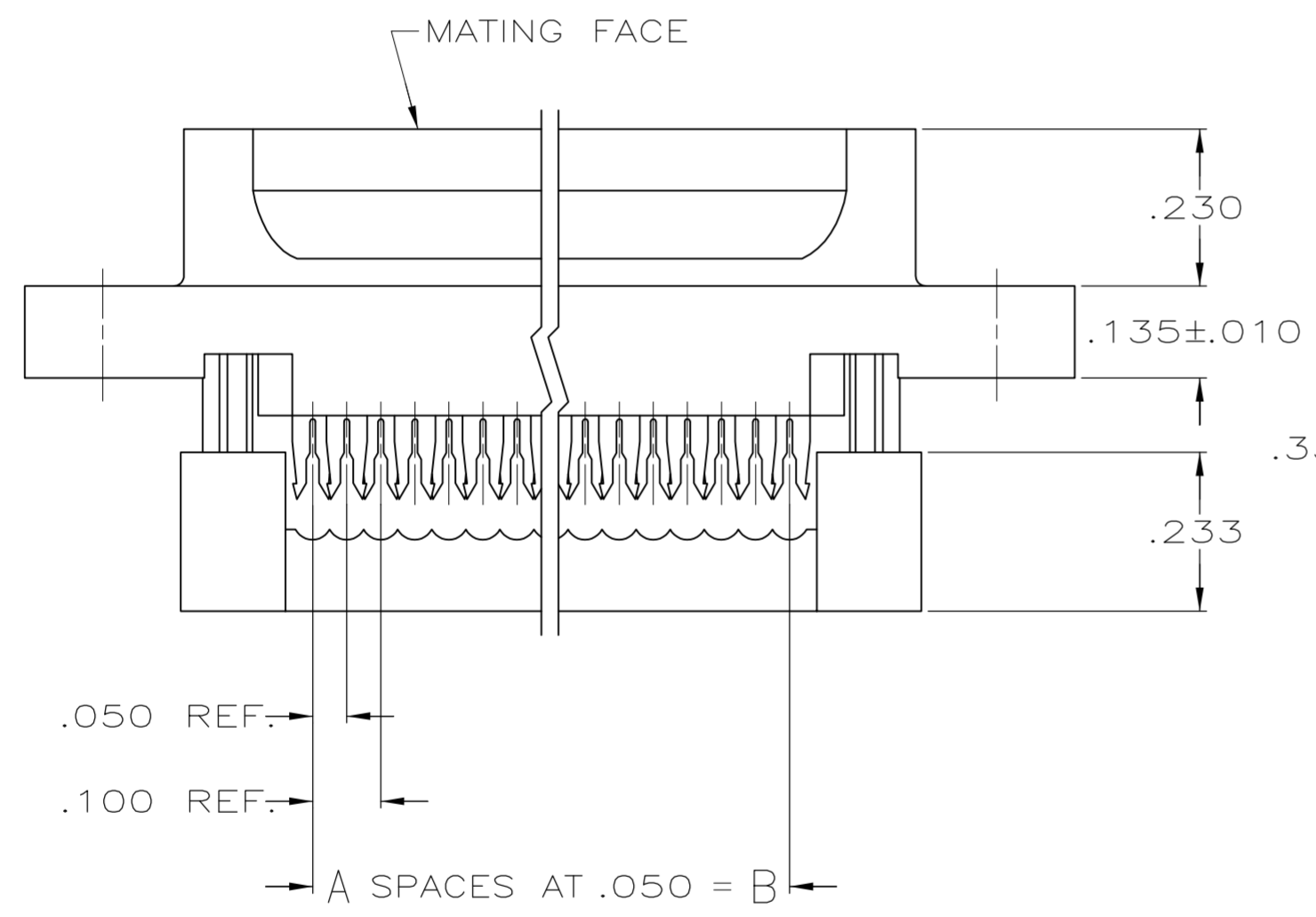

	1.216	.984	.759	.666	.400	8	9	1658611-4
	1.541	1.312	1.067	.994	.700	14	15	1658611-3
	2.090	1.852	1.623	1.534	1.200	24	25	1658611-2
OBSOLETE	2.732	2.500	2.275	2.183	1.800	36	37	1658611-1
	F	E	D	C	B	A	NO.OF POS.	PART NUMBER

THIS DRAWING IS A CONTROLLED DOCUMENT.

DIMENSIONS: INCHES	TOLERANCES UNLESS OTHERWISE SPECIFIED:	DWN B. MCMASTER 31MAR04	Tyco Electronics Corporation Harrisburg, PA 17105-3608
	0 PLC ± -	CHK C. ROHDE 31MAR04	
	1 PLC ± -	APVD M. WALMSLEY 31MAR04	
	2 PLC ± -	PRODUCT SPEC	
MATERIAL	FINISH	APVD M. WALMSLEY 31MAR04	NAME
		APPLICATION SPEC	PLUG ASSEMBLY, THREADED INSERTS, LEAD-FREE, AMPLIMITE HDF
		WEIGHT -	SIZE A2
			CAGE CODE 00779
			DRAWING NO C=1658611
			RESTRICTED TO -
			SCALE 4:1
			SHEET 1 of 1
			REV D

CUSTOMER DRAWING

1658611